

AIP704E00HAE00X

The right to introduce technical modifications is reserved

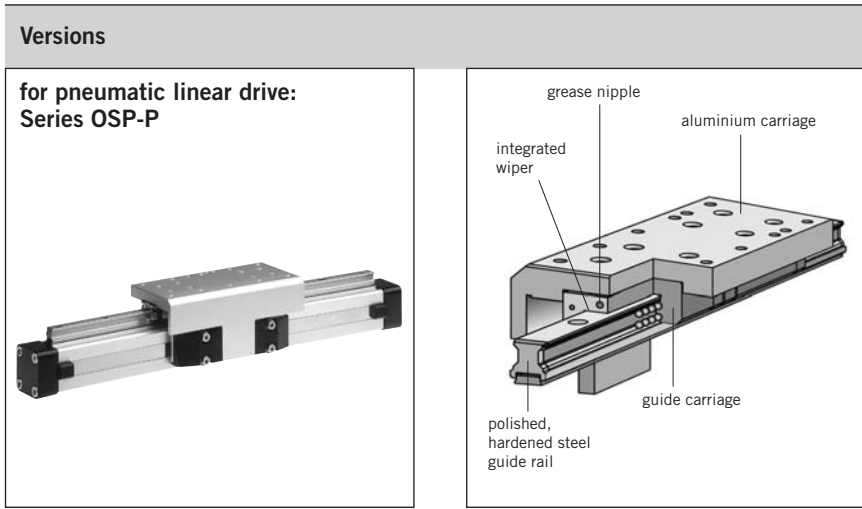

Recirculating Ball Bearing Guide STARLINE



Series STL 16 to 50
for Linear Drive Series OSP-P

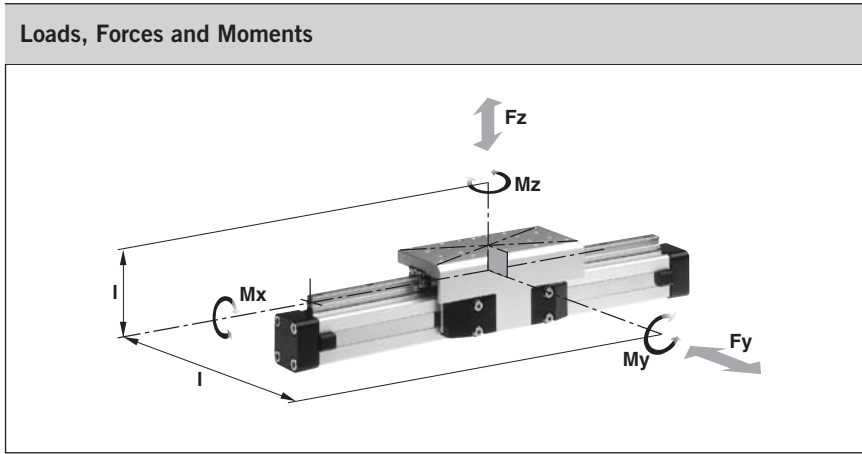

Technical Data

The table shows the maximum permissible loads. If multiple moments and forces act upon the cylinder simultaneously, the following equation applies:

$$\frac{M_x}{M_{x_{max}}} + \frac{M_y}{M_{y_{max}}} + \frac{M_z}{M_{z_{max}}} + \frac{F_y}{F_{y_{1max}}} + \frac{F_z}{F_{z_{max}}} \leq 1$$

The sum of the loads should not exceed >1

The table shows the maximum permissible values for light, shock-free operation, which must not be exceeded even under dynamic conditions.

Features:

- Polished and hardened steel guide rail
- For very high loads in all directions
- High precision
- Integrated wiper system
- Integrated grease nipples
- Any length of stroke up to 3700 mm
- Anodized aluminium guide carriage – dimensions compatible with OSP guides SLIDELINE and PROLINE
- Installation height (STL16 - 32) compatible with OSP guides SLIDELINE and PROLINE
- Maximum speed
STL16: v = 3 m/s
STL25 to 50: v = 5 m/s

** Please note:

The mass of the carriage has to be added to the total moving mass when using the cushioning diagram.

Series	For linear drive	Max. moments [Nm]			Max. loads [N]		Mass of linear drive with guide [kg]		Mass ** guide carriage [kg]	Order No. STARLINE for OSP-P
		Mx	My	Mz	Fy	Fz	with 0 mm stroke	increase per 100 mm stroke		
STL16	OSP-P16	15	30	30	1000	1000	0.598	0.210	0.268	21111
STL25	OSP-P25	50	110	110	3100	3100	1.733	0.369	0.835	21112
STL32	OSP-P32	62	160	160	3100	3100	2.934	0.526	1.181	21113
STL40	OSP-P40	150	400	400	4000	7500	4.452	0.701	1.901	21114
STL50	OSP-P50	210	580	580	4000	7500	7.361	0.936	2.880	21115

For linear drives see 1.10.002E
For mountings see 1.45.005E



Dimensions Series OSP-P STL16 to STL 50

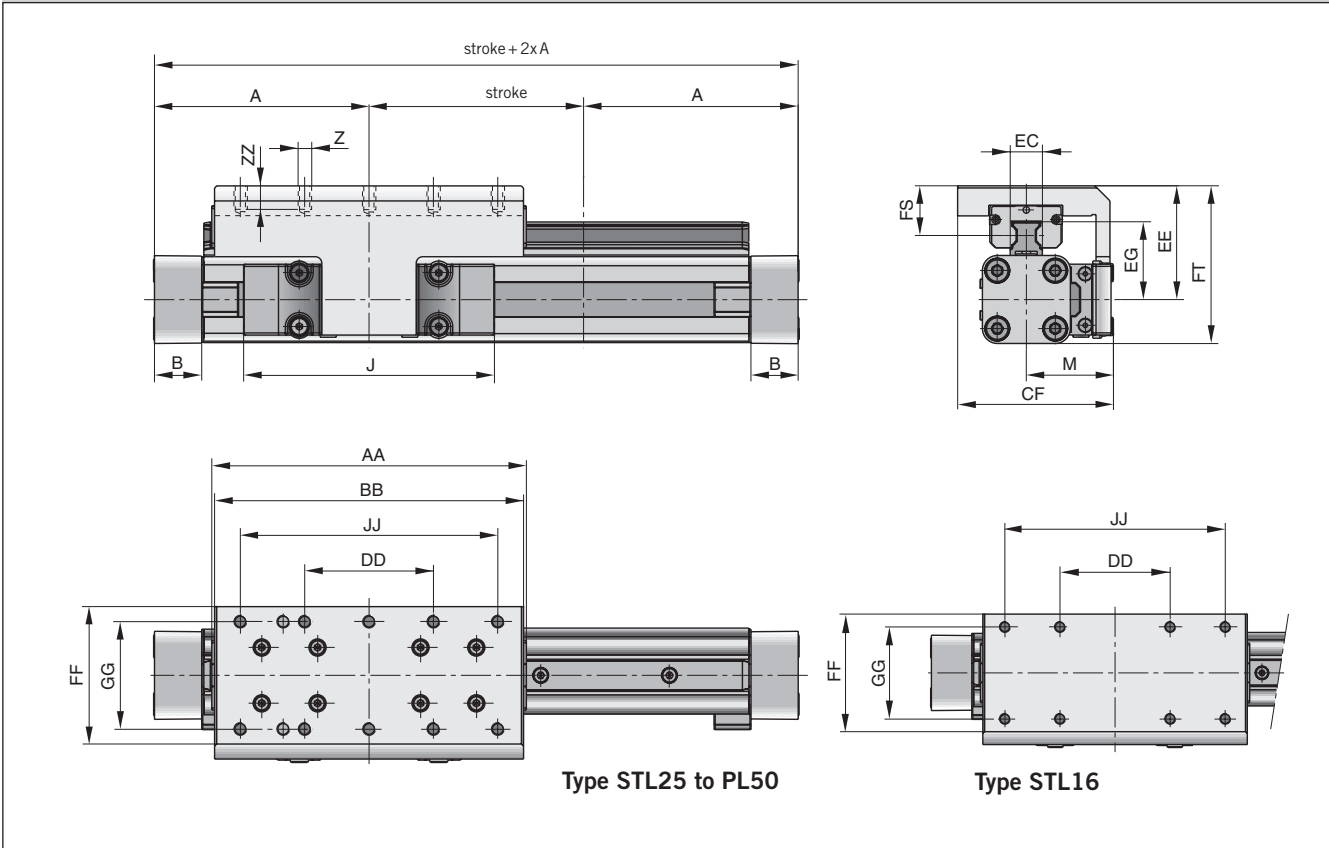

Dimension Table (mm) Series OSP-P STL16 to STL50

Series	A	B	J	M	Z	AA	BB	CF	DD	EC	EE	EG	FF	FS	FT	GG	JJ	ZZ
STL16	65	14	69	31	M4	93	90	55	30	15	40	24.6	48	18	55	36	70	8
STL25	100	22	117	40.5	M6	146.6	144	72.5	60	15	53	36.2	64	23.2	73.5	50	120	12
STL32	125	25.5	152	49	M6	186.6	184	91	80	15	62	42.2	84	26.2	88	64	160	12
STL40	150	28	152	55	M6	231	226	102	100	20	72	51.6	94	28.5	106.5	78	200	12
STL50	175	33	200	62	M6	270.9	266	117	120	23	85	62.3	110	32.5	128.5	90	240	16

Permissible Unsupported Length STL16 to STL50

Loading 1 – Top carrier

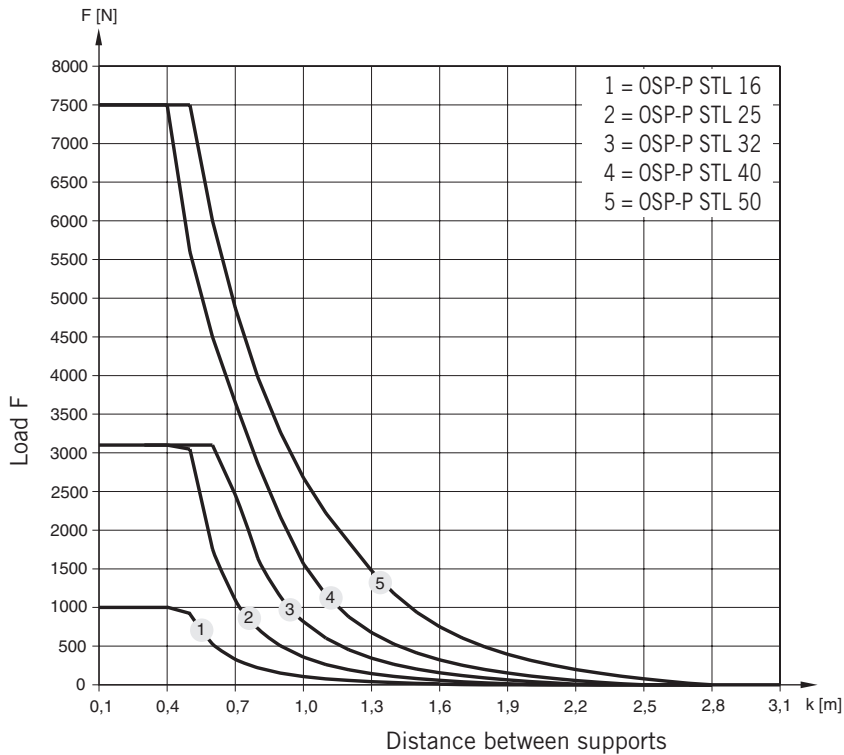

Permissible Unsupported Length STL16 to STL50

Loading 2 – Side carrier

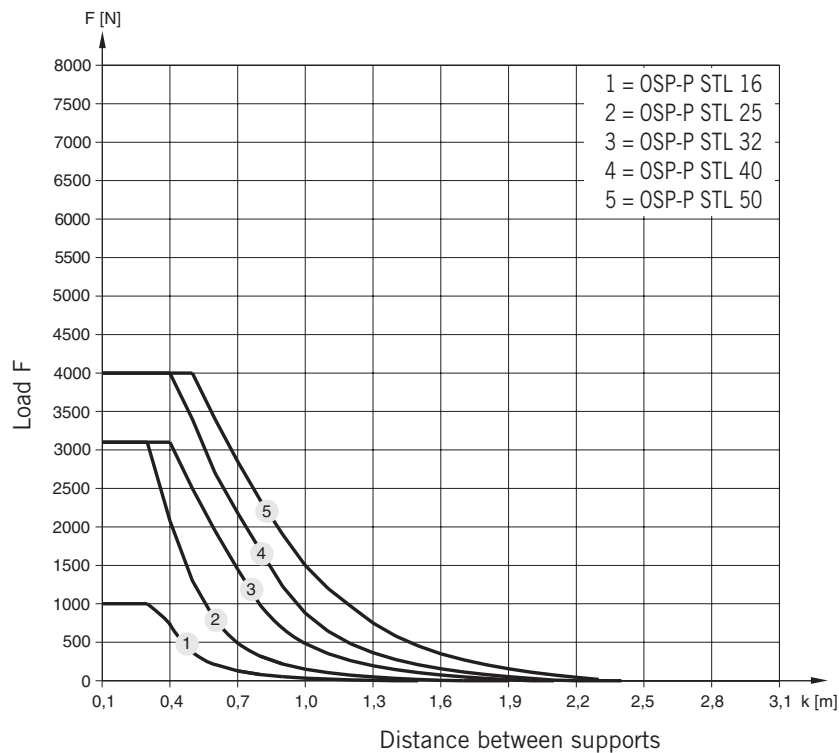

Mid-Section Support

(For versions, see 1.45.005E-8, 1.45.005E-9)

Mid-section supports are required from a certain stroke length to prevent excessive deflection and vibration of the linear drive. The diagrams show the maximum permissible unsupported length in relation to loading. A distinction must be drawn between loading 1 and loading 2. Deflection of 0.5 mm max. between supports is permissible.

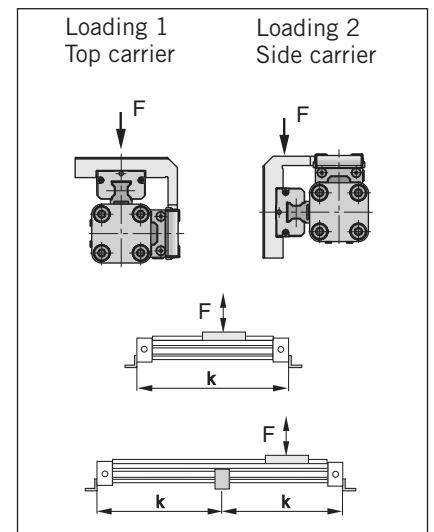

Note:

For speeds $v > 0.5$ m/s the distance between supports should not exceed 1 m.

Variable Stop

The variable stop Type VS provides simple stroke limitation.

It can be retrofitted and positioned anywhere along the stroke length. For every cylinder diameter two types of shock absorber are available – see „Shock Absorber Selection“ below.

Mid-section supports and magnetic switches can still be fitted on the same side as the variable stop.

Depending on the application, two variable stops can be fitted if required.

Variable Stop Type VS16 to VS50

Arrangement with two variable stops

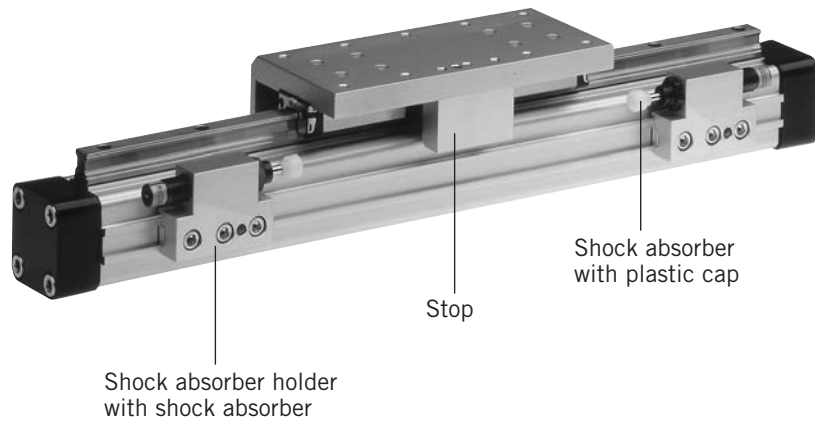

Shock Absorber Selection

The shock absorber is selected in dependence on the mass and speed.

The mass of the carrier itself must be taken into account.

Shock Absorber Selection in Dependence on Mass and Speed for Series OSP-STL16

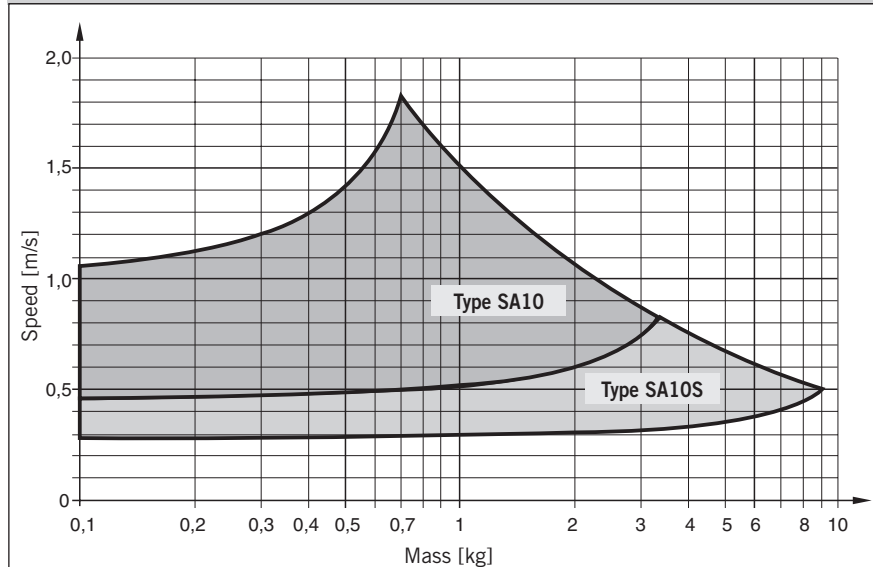

The values relate to an effective driving force of 78 N (6 bar)

Shock Absorber Selection in Dependence on Mass and Speed for Series OSP-STL25

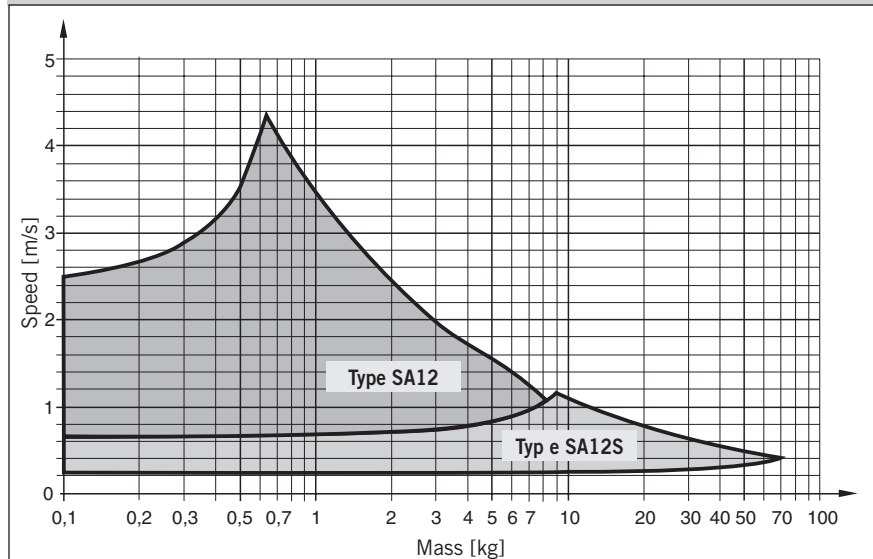

The values relate to an effective driving force of 250 N (6 bar)

Shock Absorber Selection in Dependence on Mass and Speed for Series OSP-STL32

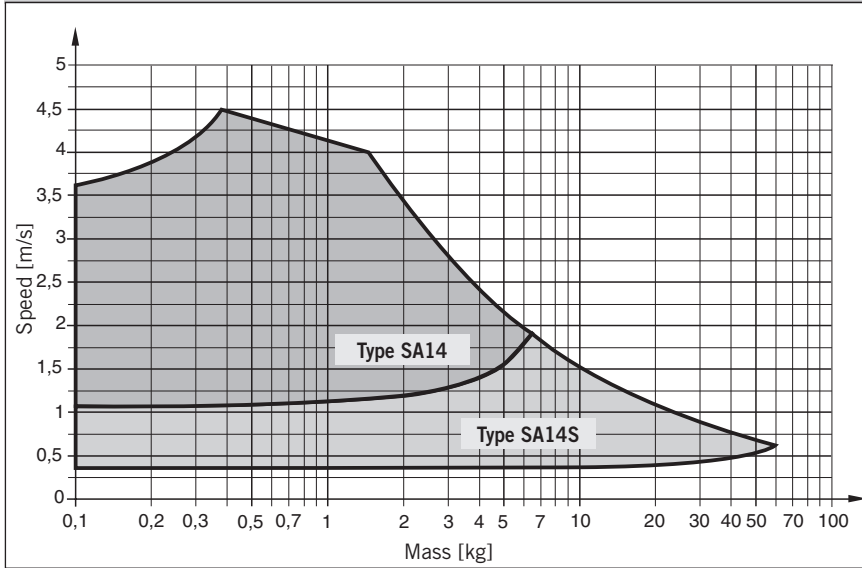

The values relate to an effective driving force of 420 N (6 bar)

Shock Absorber Selection in Dependence on Mass and Speed for Series OSP-STL40

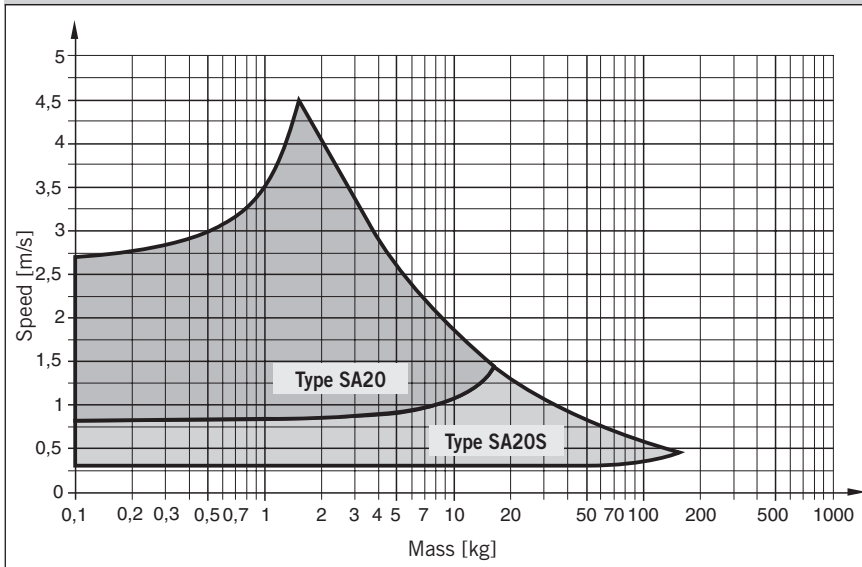

The values relate to an effective driving force of 640 N (6 bar)

Shock Absorber Selection in Dependence on Mass and Speed for Series OSP-STL50

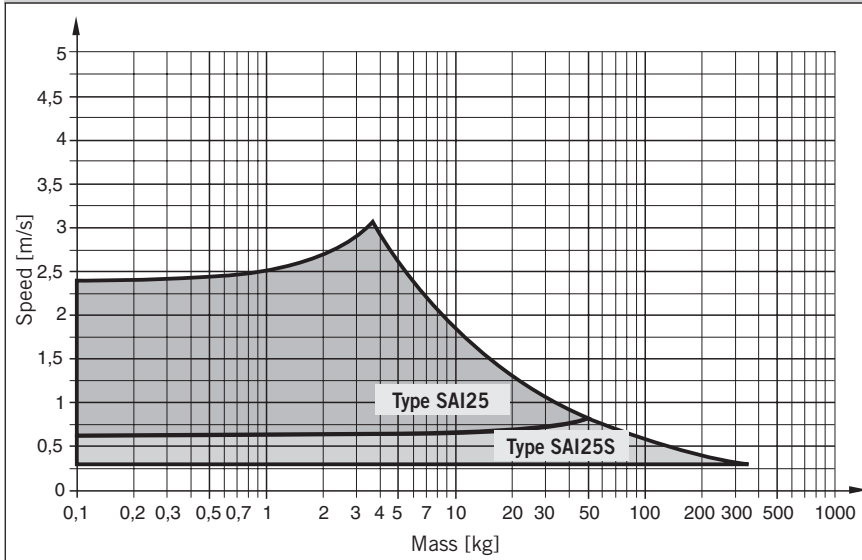

The values relate to an effective driving force of 1000 N (6 bar)

Dimensions – Variable Stop Type VS16 to VS50

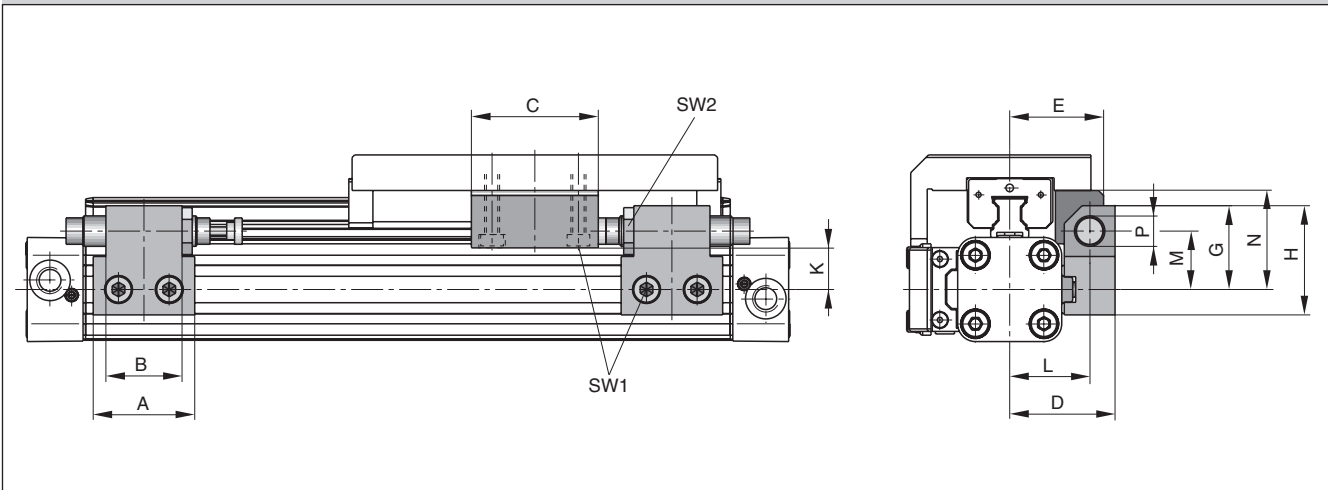

Dimension Table (mm) – Variable Stop Type VS16 to VS50

Series	Type	A	B	C	D	E	G	H	K	L	M	N	P	SW1	SW2
OSP-STL16	VS16	30	14	25	33	30	28	38	16.2	25.5	20.5	30	M10x1	4	12.5
OSP-STL25	VS25	40	30	50	41.5	37	33	43	18	31.5	23	39	M12x1	5	16
OSP-STL32	VS32	60	40	50	45.5	42	35	45	19	35.5	25	48	M14x1.5	5	17
OSP-STL40	VS40	84	52	60	64	59	48	63	25.6	50	34	58.6	M20x1.5	5	24
OSP-STL50	VS50	84	-	60	75	69	55	70	26.9	57	38	66.9	M25x1.5	5	30

Order Information – Variable Stop Type VS16 to VS50

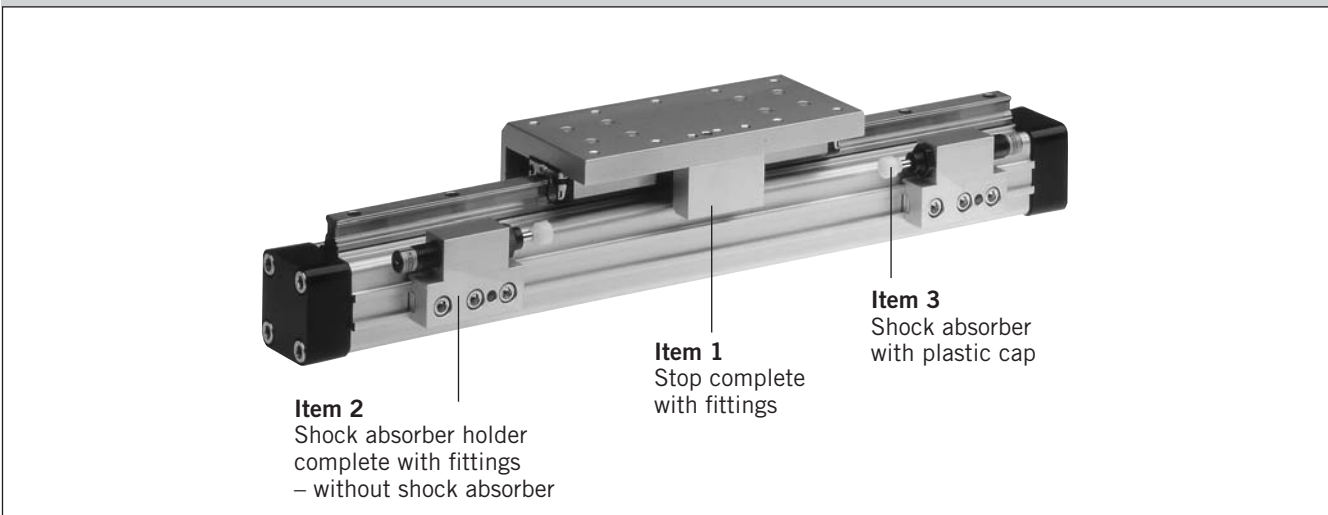

Order Instructions – Variable Stop Type VS16 to VS50

Item	Description	Size VS16		VS25		VS32		VS40		VS50	
		Type	Order No.	Type	Order No.	Type	Order No.	Type	Order No.	Type	Order No.
1	Stop, complete	-	21196	-	21197	-	21198	-	21199	-	21200
2	Shock absorber holder, complete	-	21201	-	21202	-	21203	-	21204	-	21205
3 *	Shock absorber, standard	SA10	7900	SA12	7706	SA14	7708	SA20	7710	SAI25	7712
	Shock absorber, version S	SA10S	7907	SA12S	7707	SA14S	7709	SA20S	7711	SAI25S	7713

* Shock absorber with plastic cap